



ORIGINAL
HENKELMAN
vacuum systems

Henkelman BV
PO Box 2117
5202 CC 's-Hertogenbosch
The Netherlands
Tel +31 (0)73 - 621 36 71
Fax +31 (0)73 - 622 13 18
info@henkelman.com
www.henkelman.com

Uw dealer

VORTEX SERIES

CREATING NATURAL PROTECTION

'CREATING NATURAL PROTECTION' STANDS FOR HENKELMAN PACKAGING MACHINES
IN THE GLOBAL MARKET AND UNIQUE COMPANY POLICY

Henkelman packaging machines ensure an optimal 'natural protection' of products in a wide variety of industries worldwide. Henkelman guarantees affordable top quality in the vacuum packaging technology. Advanced engineering, modular construction and well-balanced design ensure that the machines perform optimally and are easy to maintain. The variety of machines and possibilities offers

the customer an optimal choice for packaging his or her product. Henkelman's company policy ensures the 'natural protection' of customers and their markets. The efficient organisation and dynamic Henkelman team ensure a constant quality and quick delivery times. Fast lines of communication combined with customer oriented support and sharp prices make Henkelman unique.



Andere Original Henkelman Series



VORTEX SERIES

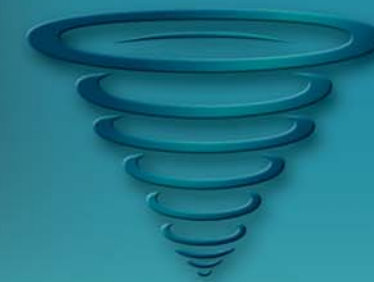

ORIGINAL
HENKELMAN
vacuum systems



CREATING
NATURAL PROTECTION





VORTEX SERIES

TRAY SEALING MACHINES WITH WORLDWIDE REPUTATION FOR FOOD AND NON-FOOD PRODUCTS

- Professional , renowned quality tray sealing machines
- Full range of Seal, Vacuum and MAP packaging options
- Extensive program choices for specific packaging requirements
- Tremendous flexibility due to easy change-over of moulds

FOOD PRODUCTS

RETAIL TRADE – WHOLESALERS – CATERING – SUPERMARKETS

- Attractive product presentation
- Easy display of information (weight, ingredients, price)
- Longer shelf life / optimal product and storage hygiene



folie kleur - speciaal bedrukt - metallic folies



VORTEX SPECIFICATIONS

GENERAL

- Floor model in stainless steel
- Insert plates for adjusting the chamber volume
- Quick mould change over
- Pressure sensor controlled

PACKAGING FUNCTIONS

- Seal only
- Vacuum and sealing
- Vacuum, Gas injection and sealing

SEALING SYSTEM

- Contour sealing
- Convex seal contact, ensuring better seal

OPERATIONAL CONTROL FUNCTIONS

- Contour cutting
- Pressure sensor controlled program
- Gas supply, Temperature, Compressed Air and Film Presence detection
- 10 programs

OPTIONAL FUNCTIONS

- Easy peel corner
- Service kit for standard maintenance
- Additional moulds

- Standard specifications
- Optional specifications

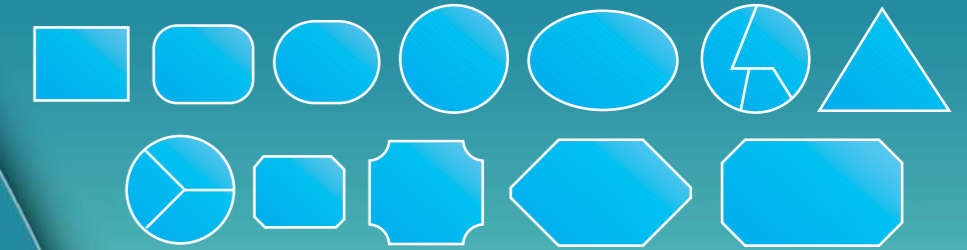
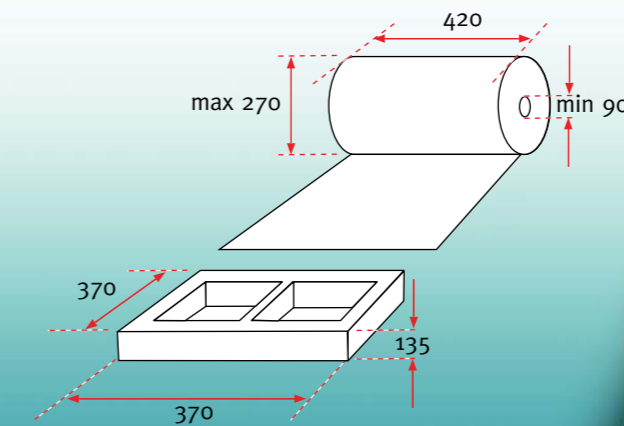

Seal en bakjes mal